

Suction Cup Phone/Camera Holder Mount

Small Volumes / Light Weight / Multi-function / Easy Operation



SHM-10

Suction Cup Phone/Camera Holder Mount



SHM-10

Material



Specifications

Model	SHM-10
Net Weight	290g / 0.6lbs

SHM-10

E-IMAGE SHM-10 phone/camera holder mount features a 8.5cm diameter twist-lock suction cup base, it has a strong hold on glass and non-porous surfaces. Included a removeable mini ball head and phone holder and pivots on a 360-degree arc for a variety of mounting positions.

Features

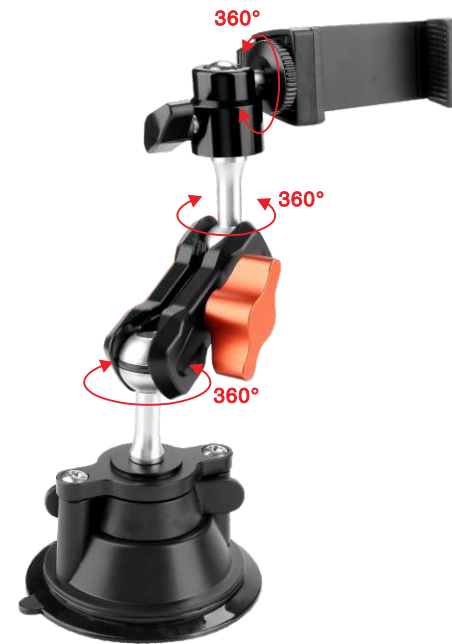

• Each joint can be 360° adjusted.

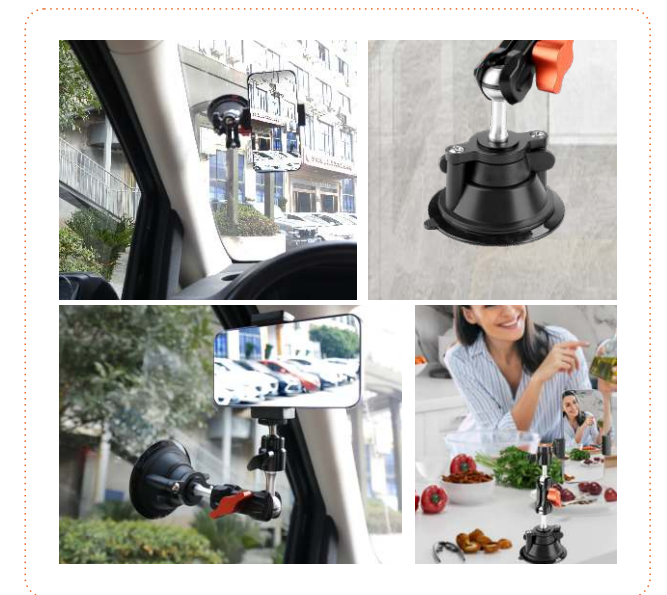

• Powerful suction cup mounts to any smooth non-porous surface.



• Ergonomic rigid lockup takes just a quick twist of one control.



• Mini ball head and the phone holder can be removable according to your own needs.



• The rotating ball joint allows you to view your phone in both landscape and portrait modes. Holds all phone and case combinations from 6cm to 9cm in width.

